



Batch Cooker

The Haarslev Batch Cooker is designed for sterilisation, hydrolysis, and drying of animal by-products. The batch cooker is one of the most important parts of a dry rendering plant and is manufactured in five standard

sizes to suit various plant capacities

Applications

The Haarslev batch cooker can be used for processing of the following animal by-products:

- Mixed meat offal and bones
- Raw blood
- Wet feathers
- Mixed poultry offal

Individual designs

The batch cooker is delivered as a unit ready to install inclusive of all necessary valves, instruments, steam trap system, safety valve, and insulation as standard.

Haarslev Industries

Haarslev Industries is one of the world's leading companies within handling and processing by-products from food related industries.

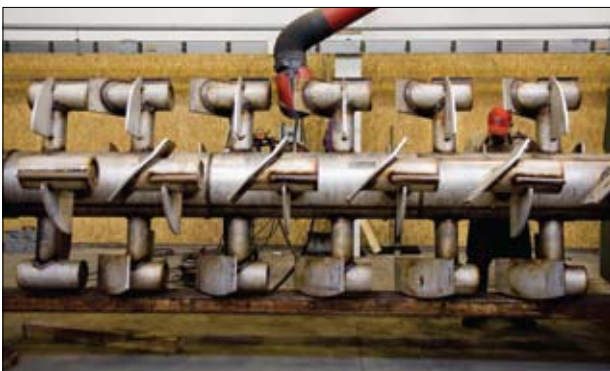

Capacities for Batch Cookers

Figures are stated as lbs per batch.

Type	Application			
	Mixed meat offal & bones	Raw blood	Wet feathers	Mixed poultry offal
BC5000	6614	4409	5952	6614
BC6500	8818	5512	7716	8818
BC8500	11023	7496	10141	11023
BC10000	13228	8818	11905	13228
BC16000	22046	15432	19842	22046

Certifications and Regulations

The design of the batch cooker complies with internationally acknowledged standards and each machine is inspected and pressure tested by authorities in accordance with pressure vessel regulations in the country in which the machine is to be installed.

Optionals

The batch cooker may be supplied with manual or automatic discharge door. We also supply additional equipment such as:

- Automatic moisture control with end point signal.
- Automatic process control equipment.
- Load cell system.

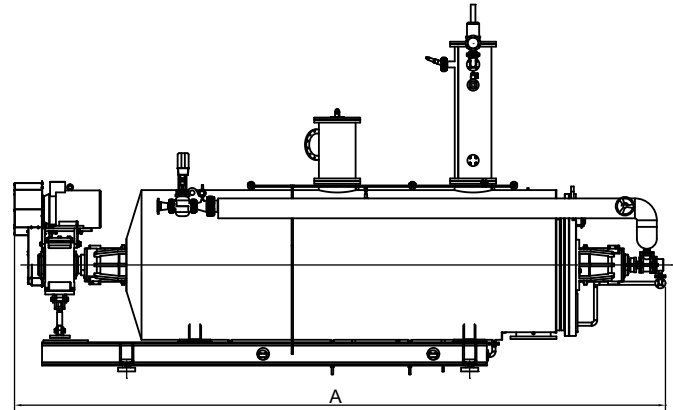
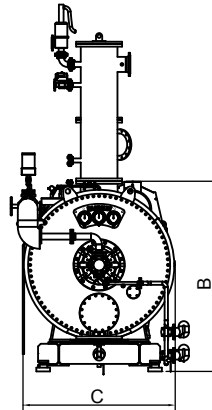

Technical specifications	Unit	Type					
		BC5000	BC6500	BC8500	BC10000	BC16000	
Dimension ^{*)}	A	inch	215	280	292	331	354
	B	inch	81	81	91	91	98
	C	inch	63	63	70	70	83
Design pressure Jacket and rotor	Psi		145	145	145	145	145
Design pressure cooker	Psi		73	73	73	73	73
Heating surface	ft ²		291	380	441	506	679
Power	HP		50	60	74	101	147
Shipping weight	lbs		26455	29762	41888	48502	79366

^{*)} All statements of dimensions are approximate.

We reserve the right to alter the specifications at any time without prior notice.



Haarslev Industries A/S • Bogensevej 85
 DK-5471 Søndero • Denmark
 Telephone: +45 63 83 11 00
 E-mail: info@haarslev.com
 www.haarslev.com

