



## PB 10/20 Crusher

The PB 10/20 Crusher is a medium size crushing machine designed for size reduction of most types of animal by-products. The crushed material can easily be transported in screw conveyors or pumps, which makes the cooking process becomes more efficient.

### General Information

- Capacity range up to 11,000 lbs of raw material per hour, including whole small carcasses.
- Consistent discharge particle size complying with the EU Directives.
- Low operation costs are assured by adjusting motor size and breaker shaft speed to the capacity required.



### Haarslev Industries

Haarslev Industries is one of the world's leading companies within handling and processing of by-products from food-related industries.

Since 2003, Haarslev Industries has integrated the famous range of pre-breakers and crushers of Sværtek. The Sværtek brand is recognized world-wide for outstanding quality and reliability.

## Technical Description

- Rotating knives and anvils are hard faced on all cutting edges.
- Shaft passage at end walls is provided with stuffing boxes as standard.
- Low-speed breaker shaft ensures that the pre-breaker can handle metals in the raw material being crushed.
- The design of the main bearing houses of the breaker shaft allows quick maintenance and replacement of breaker shaft.
- Removable counter flanges fitted to the inlet and outlet as standard.
- Inlet hopper and supports are made to measure upon request.

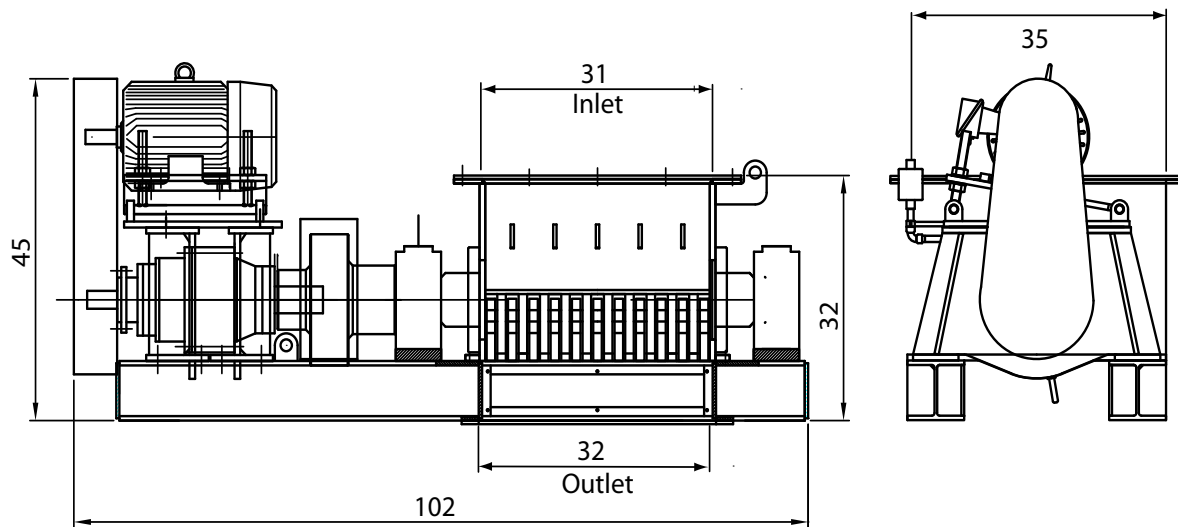

Technical Specifications	Unit	Type PB10/20
Capacity	lbs/h	2,200-11,000
Gap between anvils	inch	2
Power/motor	HP	25
Shipping weight	lbs	7,052

We reserve the right to alter the specifications at any time without prior notice.



Haarslev Industries A/S • Bogensevej 85  
 DK-5471 Søndero • Denmark  
 Telephone: +45 63 83 11 00  
 E-mail: [info@haarslev.com](mailto:info@haarslev.com)  
[www.haarslev.com](http://www.haarslev.com)

