



## PB 30/60 Crusher

The PB 30/60 Crusher from Haarslev A/S is the ultimate crushing machine that can process all normal types of animal by-products.

This single-pass crusher discharges a particle size suitable for feeding via any conveying system into batch cookers or directly into all types

of continuous cookers typically used in rendering operations.

Haarslev Crushers and Pre-breakers have been installed in hundreds of rendering plants worldwide over the past 35 years, and Haarslev Industries is the established leader in crushing machines for the rendering industry.

- Consistent discharge particle size complying with the EU Directives and small enough for feeding directly into all types of continuous cookers.

### Haarslev Industries

Haarslev Industries is one of the world's leading companies within handling and processing of by-products from food-related industries.

Since 2003 Haarslev Industries has integrated the famous range of pre-breakers and crushers of Sværtek. The Sværtek brand is recognised world-wide for outstanding quality and reliability.

### General description

- Wide capacity range: Up to 50 tons of raw material per hour, including whole carcasses.
- Low operation costs are assured by adjusting motor size to breaker shaft speed.



## Technical Description and Features

- Low-speed breaker shaft ensures that the PB 30/60 Crusher can handle metals in the raw material.
- Rotating knives and anvils are made of special alloy steel, which can be rebuilt by welding and hard facing.
- Rotating knives and anvils are replaceable and interchangeable. Each anvil can be turned around 180 degrees and can be used twice before rebuilding.
- Breaker shaft main bearing houses are fitted into tapered guides, which allow quick breaker shaft maintenance and replacement.
- Shaft passages at end walls are provided with stuffing boxes.
- Removable counterflanges fitted to the inlet and outlet, are standard.
- Inlet hopper and supports are made to measure upon request.
- Electric panel complete with controls and motor starter is available upon request.

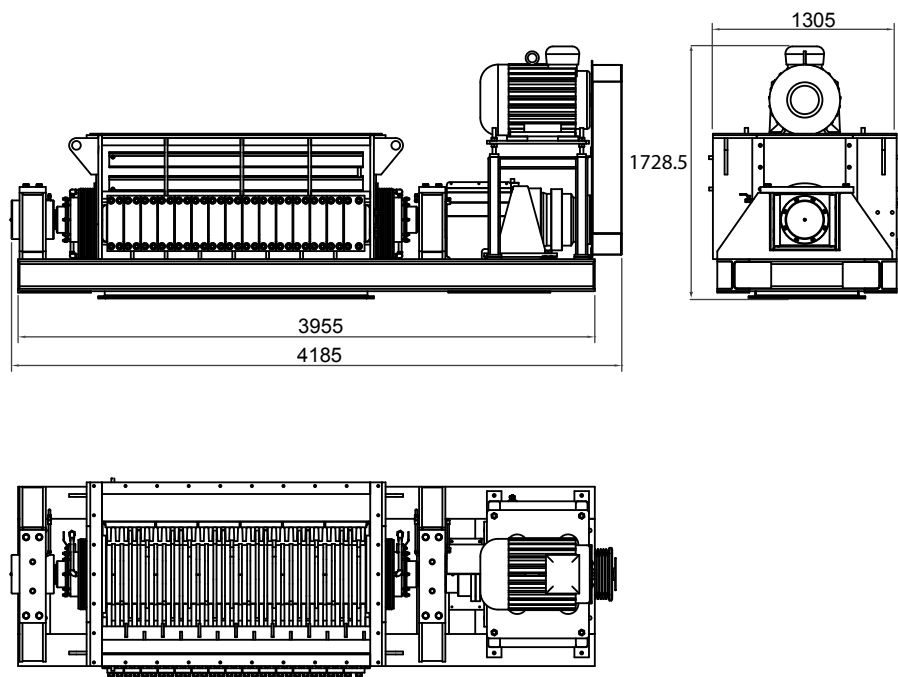

Technical Specifications	Unit	Type PB 30/60
Capacity	t/h	10 - 50
Anvil Gap	mm	25
Power/motor	kW	37 - 75
Breaker shaft	rpm	20 - 65
Shipping weight less motor	kg	9,000

We reserve the right to alter the specifications at any time without prior notice.



Haarslev Industries A/S • Bogensevej 85  
 DK-5471 Søndero • Denmark  
 Telephone: +45 63 83 11 00  
 E-mail: [info@haarslev.com](mailto:info@haarslev.com)  
[www.haarslev.com](http://www.haarslev.com)

