



PB 30/60 Crusher

The PB 30/60 Crusher from Haarslev A/S is the ultimate crushing machine that can process all normal types of animal by-products.

This single-pass crusher discharges a particle size suitable for feeding via any conveying system into batch cookers or



directly into all types of continuous cookers typically used in rendering operations.

Haarslev Crushers and Pre-breakers have been installed in hundreds of rendering plants worldwide over the past 35 years, and Haarslev Industries is the established leader in crushing machines for the rendering industry.

General description

- Wide capacity range: Up to 110,000 lbs of raw material per hour, including whole carcasses.
- Low operation costs are assured by adjusting motor size to breaker shaft speed.

- Consistent discharge particle size complying with the EU Directives and small enough for feeding directly into all types of continuous cookers.

Haarslev Industries

Haarslev Industries is one of the world's leading companies within handling and processing of by-products from food-related industries.

Since 2003, Haarslev Industries has integrated the famous range of pre-breakers and crushers of Sværtek. The Sværtek brand is recognized world-wide for outstanding quality and reliability.

Technical Description and Features

- Low-speed breaker shaft ensures that the PB 30/60 Crusher can handle metals in the raw material.
- Rotating knives and anvils are made of special alloy steel, which can be rebuilt by welding and hard facing.
- Rotating knives and anvils are replaceable and interchangeable. Each anvil can be turned around 180 degrees and can be used twice before rebuilding.
- Breaker shaft main bearing houses are fitted into tapered guides, which allow quick breaker shaft maintenance and replacement.
- Shaft passages at end walls are provided with stuffing boxes.
- Removable counterflanges fitted to the inlet and outlet, are standard.
- Inlet hopper and supports are made to measure upon request.
- Electric panel complete with controls and motor starter is available upon request.

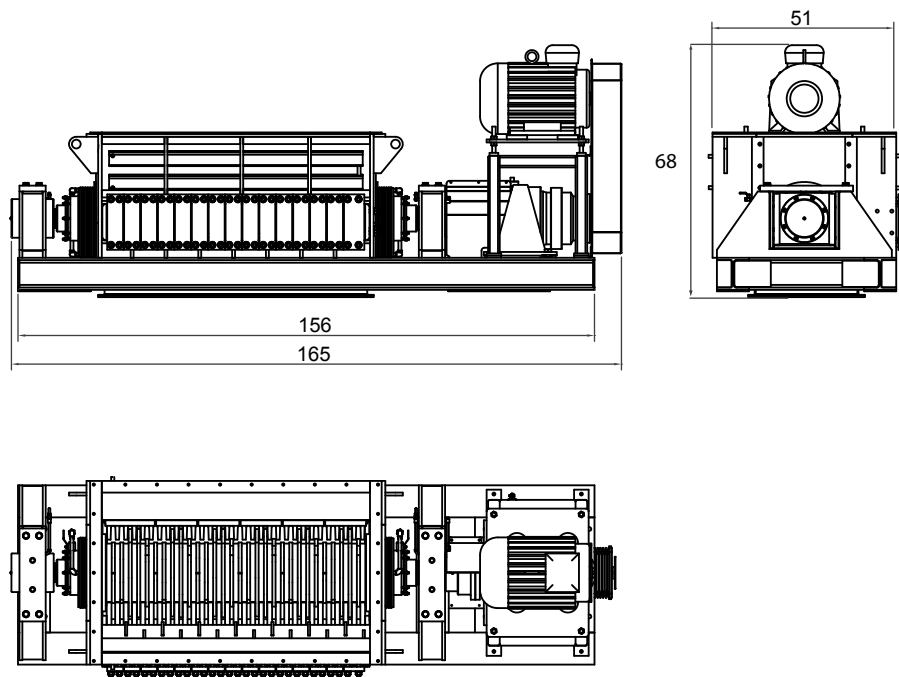

Technical Specifications	Unit	Type PB 30/60
Capacity	lbs/h	22,000-110,000
Anvil Gap	inch	1
Power/motor	HP	50 - 100
Breaker shaft	rpm	20 - 65
Shipping weight less motor	lbs	19,842

We reserve the right to alter the specifications at any time without prior notice.



Haarslev Industries A/S • Bogensevej 85
 DK-5471 Sønderso • Denmark
 Telephone: +45 63 83 11 00
 E-mail: info@haarslev.com
 www.haarslev.com

