



Haarslev Fine Crusher

The Haarslev Fine Crusher is designed for particle size reduction of animal by-products.

Applications

The Fine Crusher can be configured to crush pre-broken raw material down to a particle size of 12 mm. The Fine Crusher can also be delivered with knives for larger particle sizes. The Fine Crusher can also be used for delumping of feathers.

The fine crusher will have a throughput capacity from 2 – 20 ton/hour depending on raw material composition and required output particle size.

Haarslev Industries

Haarslev Industries is one of the world's leading companies within handling and processing of by-products from food-related industries.

Since 2003 Haarslev Industries has integrated the well-known range of pre-breakers and crushers of Sværtek. The Sværtek brand is recognized world-wide for outstanding quality and reliability. Pre-breakers and crushers from Haarslev Industries have been installed in hundreds of rendering plants worldwide over the past decades.

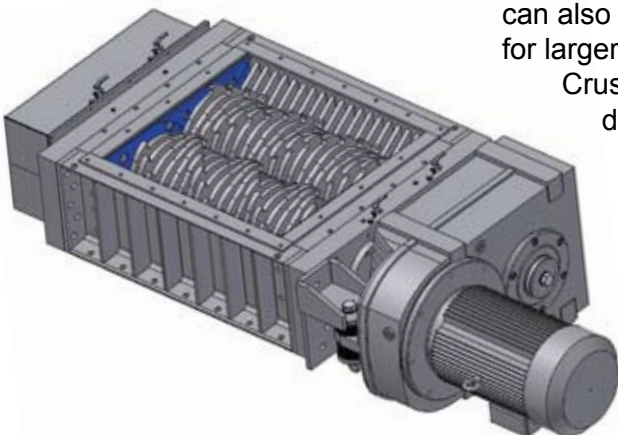

Technical Description

The fine crusher is designed with two parallel counter rotating crusher shafts. The two crusher shafts are driven by one heavy-duty gear motor with one set of internal gears connecting the two shafts.

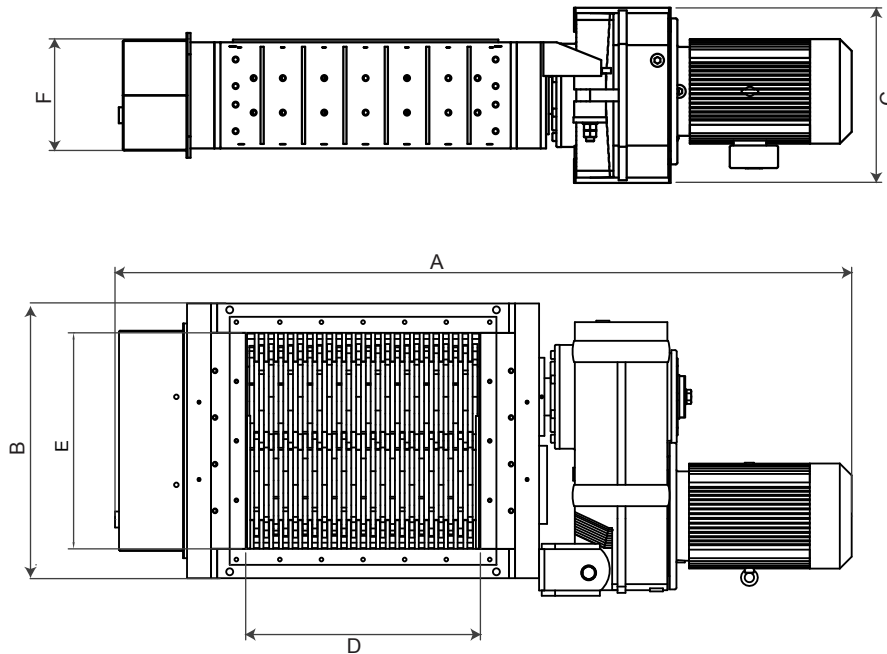

Each shaft is supported in spherical roller bearings with mechanical seals to ensure maximum performance with minimum down time.

The crusher shafts are fitted with replaceable, machined cutting blades.

Technical Specifications	Unit	Type		
		FC23/37	FC18/47	FC13/55
Capacity	th. lbs/h	22 - 40	22 - 40	7 - 33
Gap between knives	inch	0.9	0.7	0.5
Dimensions	A	inch	109	109
	B	inch	41	41
	C	inch	26	26
	D	inch	35	35
Inlet/outlet	E	inch	32	32
	F	inch	16	16
Power/motor	HP	60	60	60
Shipping weight less motor	lbs	7716	7716	7716

We reserve the right to alter the specifications at any time without prior notice.



Haarslev Industries A/S • Bogensevej 85
 DK-5471 Sønderso • Denmark
 Telephone: +45 63 83 11 00
 E-mail: info@haarslev.com
www.haarslev.com

