



Frozen Block Crusher

Haarslev Frozen Block Crusher is an excellent choice when effective crushing of large blocks of frozen animal by-products is required.

The crusher is supplied in two different configurations. The single shaft crusher for frozen blocks and low capacities up to 33,000 lbs per hour and the double shaft crusher for whole pallets of frozen blocks and with an output of up to 220,000 lbs per hour.

Both crusher types have a close knife configuration which gives a small particle size.

The frozen block crusher is suitable for a wide range of applications in many industries where large capacities are required.

Haarslev Industries

The wide range of crushers and pre-breakers from Haarslev Industries incorporate years of experience and knowledge from the Svaertek crushers. Since 2003 The well-reputed brand of Sværtek is recognized world-wide for outstanding quality and reliability.



All Haarslev solutions are tailormade and the frozen block crushers can be supplied to fit most applications with a wide range of hoppers, mounting frames, feed and discharge systems according to customer specifications.



Double shaft frozen block crusher



Single shaft frozen block crusher

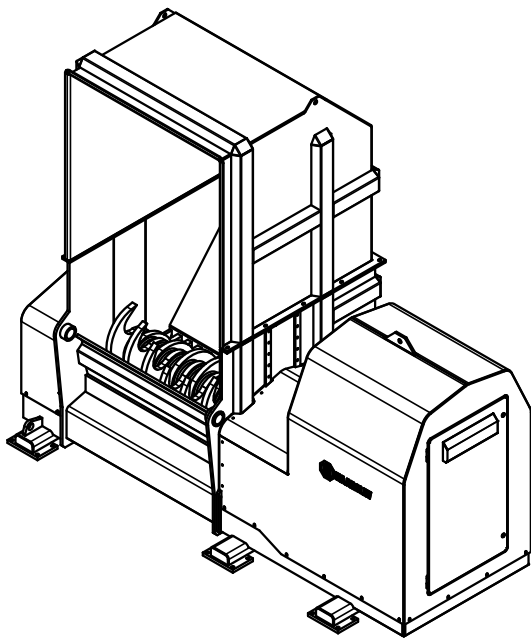

Advantages

- Wide range of capacities
- Easy to clean and maintain
- Accessories designed to customer specifications

Technical Specifications

- Heavy duty transmission
- Separation between hopper and drive ends prevents contamination.
- Motor power dependant on size of unit and the material being processed.

Technical Specifications	Unit	Type	
		FZ-15	FZ-15 Twin
Capacity (approx.)	1,000 lbs/h	33	220
Anvil gap	inch	2	4
Power/motor	HP	100	2 x 75
Weight	lbs	20,000	35,000

We reserve our right to alter the specifications at any time without prior notice.



Haarslev Industries A/S • Bogensevej 85
 DK-5471 Sønderso • Denmark
 Telephone: +45 63 83 11 00
 E-mail: info@haarslev.com
 www.haarslev.com

