



Haarslev Continuous CFH Hydroliser

The Haarslev series of continuous hydrolisers are the most advanced and easy to operate units available. The hydrolizers are specifically designed for the processing of feathers and hog hair. When engineering the CFH Hydroliser we draw on many years of experience from the rendering industry. The result is a highly reliable and energy efficient hydroliser.

These features combined with our expert technical services and spare parts make the Continuous Hydroliser from Haarslev Industries the best choice for your rendering plant.

Main features

- Continuous automated operation.
- Special main shaft designed to ensure efficient and uniform hydrolysatation.
- Safeguards against plug feed loss.

Haarslev Industries

Haarslev Industries is one of the world's leading companies within handling and processing of by-products from food-related industries.

Based on the competence already aquired from the non-edible food industry a product line for the pet food industry has been developed.

Advantages

- Only one pressurised packing gland to maintain.
- Available in carbon or stainless steel material or a combination of both.
- Low steam consumption.
- Supplied as one complete unit incl. all necessary instruments and valves.

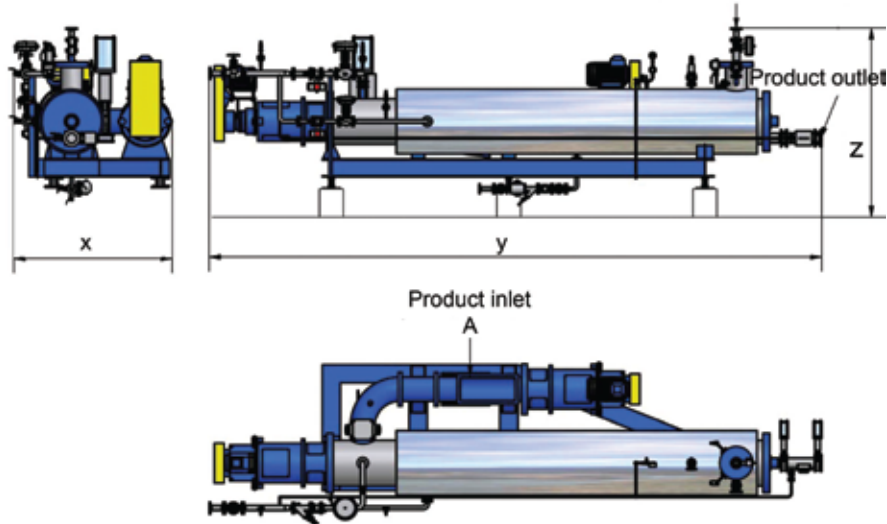

Technical specifications

	Unit	Type			
		CFH-25	CFH-50	CFH-75	CFH-120
Capacity	t/h	2.5	5.0	7.5	12.0
A inlet	mm	925x405	925x405	925x405	925x455
x	mm	2450	2600	2650	3000
y	mm	7250	9250	10250	10950
z	mm	2900	3100	3200	3450
Weight	mt	12	15	16	18
Power, feeder	kW	22	37	45	55
Power, hydroliser	kW	15	18.5	22	30

All statements of dimensions are approximate.

We reserve the right to alter the specifications at any time without prior notice.



Haarslev Industries A/S • Bogensevej 85
 DK-5471 Sønderso • Denmark
 Telephone: +45 63 83 11 00
 E-mail: info@haarslev.com
 www.haarslev.com

