



Haarslev CFH Hydrolizer

The Haarslev series of Continuous Hydrolizers are the most advanced and easy to operate units available. The hydrolizers are specifically designed for the processing of feathers and hog hair. When engineering the CFH Hydrolizer we draw on many years of experience from the rendering industry. The result is a highly reliable and energy efficient hydrolizer.

These features combined with

our expert technical services and spare parts make the Continuous Hydrolizer from Haarslev Industries the best choice for your rendering plant.

Main features

- Continuous automated operation.
- Special main shaft designed to ensure efficient and uniform hydrolysis.
- Safeguards against plug feed loss.

Haarslev Industries

Haarslev Industries is one of the world's leading companies within handling and processing of by-products from food-related industries.

Based on the competence already acquired from the non-edible food industry a product line for the pet food industry has been developed.

Advantages

- Only one pressurized packing gland to maintain.
- Available in carbon or stainless steel material or a combination of both.
- Low steam consumption.
- Supplied as one complete unit incl. all necessary instruments and valves.

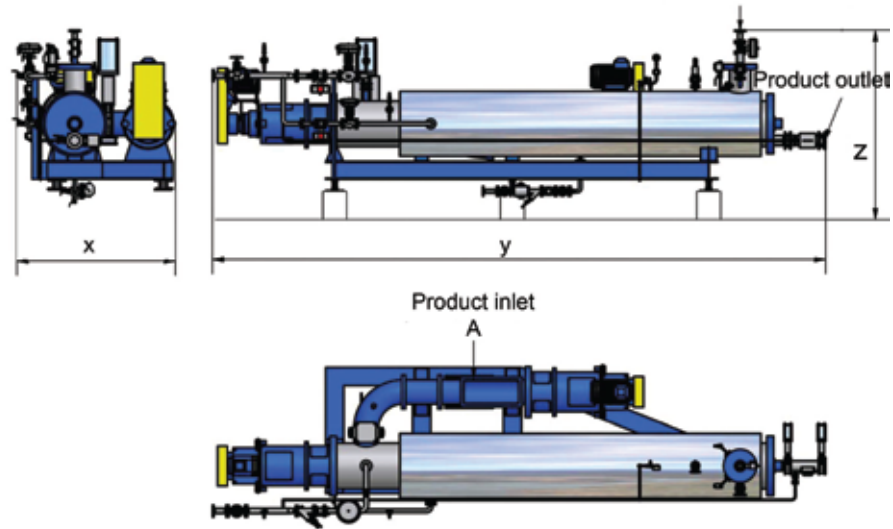

Technical specifications

	Unit	Type			
		CFH-25	CFH-50	CFH-75	CFH-120
Capacity	lbs/h	5,510	11,000	16,500	26,500
A Inlet	inch	36x16	36x16	36x16	36x18
x	inch	96	102	104	118
y	inch	285	364	404	431
z	inch	114	122	126	136
Weight	lbs	26,455	33,069	35,825	39,683
Power, feeder	HP	29	50	60	74
Power, hydrolizer	HP	20	25	29	40

All statements of dimensions are approximate.

We reserve the right to alter the specifications at any time without prior notice.



Haarslev Industries A/S • Bogensevej 85
 DK-5471 Sønderso • Denmark
 Telephone: +45 63 83 11 00
 E-mail: info@haarslev.com
www.haarslev.com

