



## Rotative Fat Drainer

The Haarslev Rotary Drainer is designed for separating free fat from cooked greaves or for screening fat and sludge from screw presses.

### Design

The separator consists of an infeed screw and a rotating perforated drum in which the separation takes place. The fat runs through the perforation, is collected in the enclosure and fed to a pump

(not included). The solids are discharged over the end of the drum.

The enclosed drum housing has a door on each side for inspection and cleaning

### Haarslev Industries

Haarslev Industries is one of the world's leading companies within handling and processing of by-products from food-related industries.

Many years of experience has given us competence in designing, manufacturing and installing processing equipment and systems for related industries, which process meat by-products or convert raw material into finished goods.

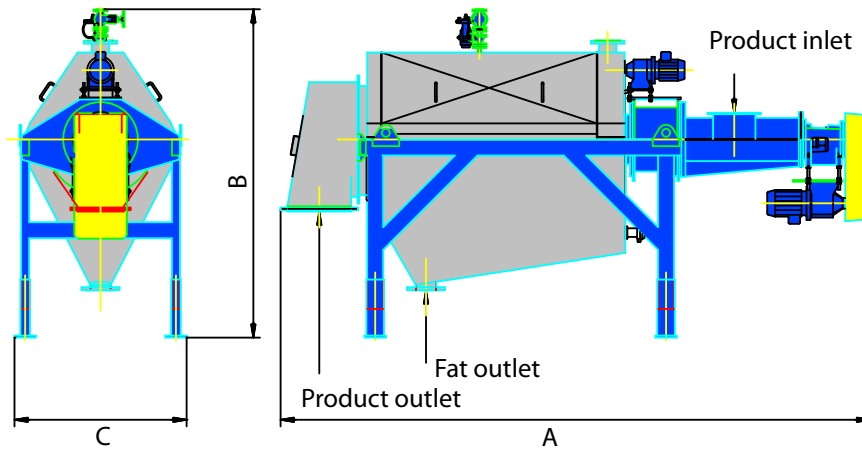

Technical Specifications		Unit	TR-50	TR-80	TR-80-5
Dimension	A	inch	154	173	250
	B	inch	87	96	112
	C	inch	41	51	51
Weight		lbs	2425	3858	5952
Diameter		inch	22	31	39
Inlet capacity		th. lbs / h	2-7	11-18	18-22
Product inlet		inch	11 x 11	12 x 12	12 x 12
Product outlet		inch	28 x 8	19 x 13	19 x 13
Power installed for separator		HP	0.50	1	2
Power installed for screw conveyor		HP	2	4	4

\*) The capacity can change depending on the percentage of solids.

We reserve the right to alter the specifications at any time without prior notice.



Haarslev Industries A/S • Bogensevej 85  
 DK-5471 Sønderso • Denmark  
 Telephone: +45 63 83 11 00  
 E-mail: info@haarslev.com  
 www.haarslev.com

