



Pressurized Steam Condensate Return System, SARC

The Haarslev SARC systems are recognised as the most significant method for producing savings in steam generation in rendering plants typically producing an overall saving of up to 15 % on steam production costs per cooker.

Conventionally, the condensate from continuous cookers and/or batch cookers is returned to the boiler feed-water tank with no special provision made to maintain condensate pressure. At the feed-water tank de-pressurization (flashing) takes place, which results in a large loss

of temperature and pressure of the condensate not to mention loss of water to the atmosphere. Energy and water is simply wasted, resulting in increased fuel consumption and increased usage of water and the chemicals used for water softening.

However, a SARC system returns steam condensate from continuous cooking and/or batch cookers directly to the boiler under pressure, by means of a steam condensate feed tank. In this way, energy losses are minimized

thereby reducing fuel and water consumption at the boiler. Boiler performance is also significantly enhanced by the SARC as the temperature of the water inside the boiler experiences less fluctuations. The SARC unit's pump has been developed with sufficient capacity and power to feed all normal steam boilers.

In order to maximize savings, each continuous cooker and/or batch cooker should be equipped with a SARC unit.

Advantages of the SARC

- Savings of approx. 15 % steam production costs for each cooker.
- Almost total elimination of water losses between cookers and boiler.
- Major savings on water treatment costs due to elimination of water losses.
- Boiler performance is enhanced.
- Elimination of visual blow offs from the feed water tank.
- Easily installed in all existing steam/condensate/steam boiler systems.

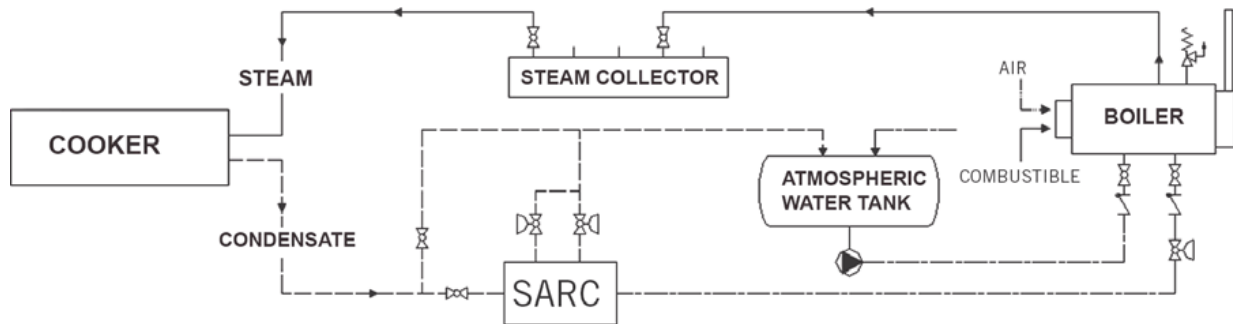

General Specifications

Model	Power (HP)	Weight lbs	Dimensions (ft)
SARC	20	2,425	3.6 x 9.5 x 10.5

We reserve the right to alter the specifications at any time without prior notice.



Haarslev Industries A/S • Bogensevej 85
 DK-5471 Sonderso • Denmark
 Telephone: +45 63 83 11 00
 E-mail: info@haarslev.com
www.haarslev.com

