



Vibrating Screen for Meal

Application

For screening of feather- or mixed poultry meal in order to remove any foreign matters, such as rubbing plucking fingers, metal and plastic.

Main advantages

- Gentle handling of product
- Efficient separation of foreign matters
- Compact design
- Low installation costs
- Low maintenance costs

Operation

The vibrating screen is provided with two motors, which make the screen vibrate. While vibrating, the product falls down through the screen's mesh and the foreign parts are being transported to the end of the screen, where they fall down into a container or a special machine.

Performance

Rated capacity for vibrating screen is app. 1.500 kg/h. Equipped with two vibrating motors each rated at 0.95 kW. Screen size 15 x 15 mm

Options

Vibration can be adjusted by a variable speed drive system.

Other screen sizes are available on request.

Haarslev Industries

Haarslev Industries is one of the world's leading companies within handling and processing of by-products from food-related industries.

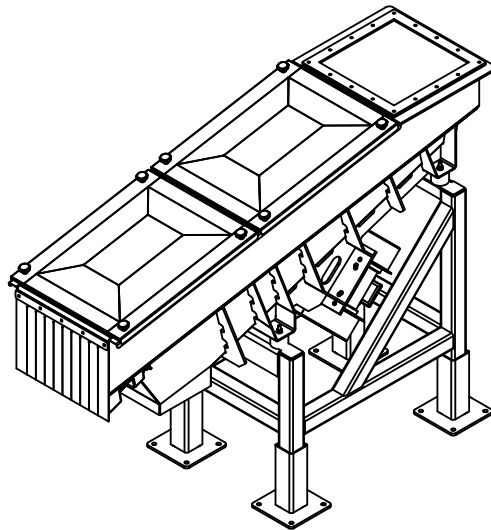
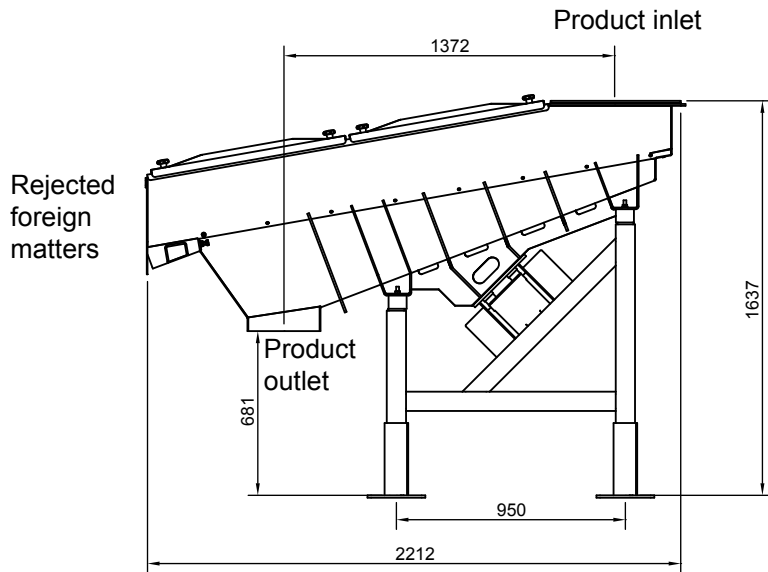

Vibrating screen	Capacity (kg/H)	Dimension (mm)			Motor Power kW	Weight in kg
		L	H	W		
HM-S-1500	1.500	2200	1650	700	2 x 0.95	460

We reserve the right to alter the specifications at any time without prior notice.



Haarslev Industries A/S • Bogensevej 85
 DK-5471 Sønderso • Denmark
 Telephone: +45 63 83 11 00
 E-mail: info@haarslev.com
www.haarslev.com

