



## Vibrating Screen for liquids

### Application

Removing of liquid from cooked fish and meat.

### Main advantages

- Gentle handling of product
- Efficient separation of liquid from solids
- Enables optimum dewatering in screw press
- Compact design
- Low installation cost
- Low maintenance cost

### Description

The Vibrating Screen is designed for optimum straining of cooked fish or meat prior to twin screw press. It consists of a screen unit mounted inside a stainless steel housing.

The screen plate is stretched over a steel frame, mounted on four brackets with rubber buffers, which reduces external vibration to a minimum and is kept in place by means of adjustable spring loaded bolts on the sides.

An eccentric shaft applies the vibration action on the screen unit.

The housing consist of two parts of which the top section can be removed for maintenance access. Inspection lids on both top and side of upper section.

### Haarslev Industries

Haarslev Industries is one of the world's leading companies within handling and processing of by-products from food-related industries.

## Specifications

The housing has flanged inlet and outlet and is equipped with four brackets for mounting on a steel support, The bottom section is V-shaped with outlet chute for liquid fraction.

## Performance

Rated capacity for Vibrating Screen 30-50 t/h of cooked fish or meat.

## Options

Different perforation of screen plates, depending on type of raw material and other characteristics. Capacity and vibration can be adjusted by variable speed drive system.

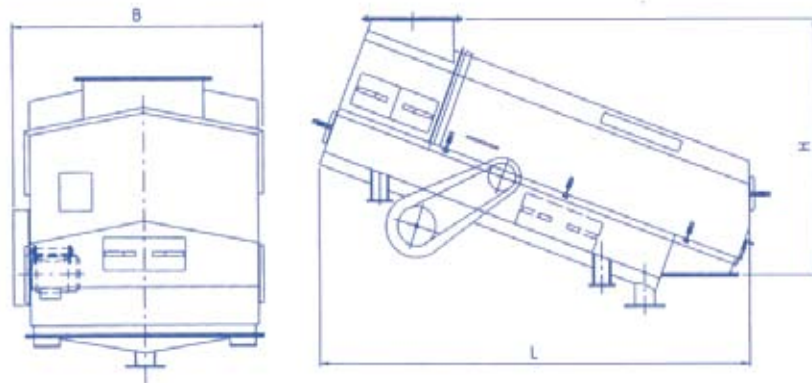

Vibrating Screen	Capacity (tons/h)	Dimension (mm)			Weight kg
		L	H	B	
3	30	2496	1455	1458	675
1230	50	3490	1825	1780	1450

*We reserve the right to alter the specifications at any time without prior notice.*



Haarslev Industries A/S • Bogensevej 85  
DK-5471 Sønderso • Denmark  
Telephone: +45 63 83 11 00  
E-mail: [info@haarslev.com](mailto:info@haarslev.com)  
[www.haarslev.com](http://www.haarslev.com)

